



External Venetian Blinds



horiso®



Horiso® External Venetian Blinds

Horiso External Venetian Blinds are one of the most versatile and effective methods of solar control in buildings. They maximise the use of incoming natural daylight while reducing glare and thermal gain. They help decrease the consumption of energy, providing long-term financial savings and benefits to the environment.

Horiso External Venetian Blinds are engineered to withstand harsh weather conditions and are available in a range of sizes, finishes and colours.

They are suitable for a variety of applications including large door and window openings up to 45 square metres.



The Bond - Sydney

Features

- ▶ Fully motorised and automated control for raising, lowering and tilting of blades.
- ▶ External Venetian Blind system components including head-rail, blades and bottom rail, have been engineered to withstand wind loads up to 77kph, snow/ice and other extreme environmental conditions.
- ▶ PVC free coated Guide wires, lift tapes and ladder cord are designed to reduce vibration due to wind.
- ▶ Wind-sensing controls tilt and retract blinds when needed.
- ▶ Blades have a polyester coil coating and stove enamelled finish.
- ▶ Perforated blades allow various degrees of openness to maintain exterior views even when blinds are fully closed.
- ▶ Width up to 6 metres and drops up to 9 metres are available. Limited to 45 square metres.

Optional Applications please see pages 6, 7, 8 and 9

Benefits

- ▶ Control of natural light, including deflecting and reflecting light onto ceilings and distributing light further into rooms.
- ▶ Privacy can be easily controlled.
- ▶ Glare from the sun is controlled, reducing eye irritation and improving computer screen visibility.
- ▶ Up to 93% reduction in heat gain entering the building; will reduce air conditioning energy consumption.
- ▶ External systems can be positioned as needed for optimal solar control and retracted when not required.
- ▶ Blades can be automatically tilted to optimise shading at varying sun angles, managing thermal gain and glare, while also utilising the natural daylight.
- ▶ Integration with intelligent controls - see page 10.
- ▶ Horiso External Venetian Blinds have been designed and built to provide years of reliable service with minimal maintenance. A five year warranty applies to all components, including operating mechanisms and controls.

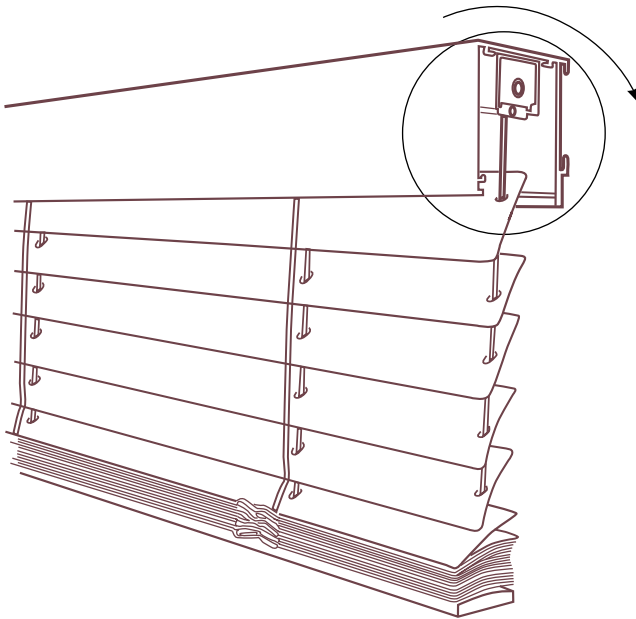

Horiso® 100mm blades. Reduced package height.

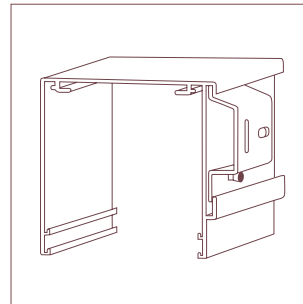

Optional aluminium extruded face fix pelmet

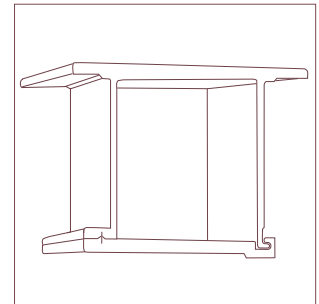

Standard aluminium extruded gate bracket

Design Specifications

Headbox

Aluminium extruded 25 microns anodised and accommodating any motor type. See page 8 for size information.

Tilting Device

Variotec-bearing with adjustable tilt. Blind lowers in the shading position (approx. 50°). When it reaches the bottom end position, the blind closes completely. Tilting device changes direction smoothly, and the blind always rises in the horizontal position. Long drop blinds have a heavy duty tilt booster device to guarantee a better tilting synchronisation.

Transverse drive/tilt shaft

Hexagonal 25 microns anodised aluminium tube, 17mm diameter, 4mm wall thickness, optionally fitted with sliding couplings at the ends.

Bearings

High load stainless steel precision ball bearings.

Ladder Cord

High-strength, shrink-resistant terylene-polyester. Includes transverse tensioning, attached or fixed to every blade positively (double omega-punching). This provides greater blade stability in strong winds.

Lifting tape

Anti-friction coated lifting tapes operate with minimum wear and tear and maximum UV-protection.

Tear proof at 750N with guaranteed thickness tolerance in the range of 1/100mm. Dimensions: 10 x 0.28mm.

Bottom Rail

Semi elliptical aluminium extrusion

Dimensions: 50 x 18.6 x 2mm

80 x 18.6 x 2mm

100 x 18.6 x 2mm

150 x 18.6 x 2mm

Surface finish includes Anodised E6-EV1, or Powder coated/stove enamelled.

Cable Guide

PVC free coated stainless steel wire tension system punched through the ends of all blades, stretched taut using various termination brackets or floor fixings.

Blades

Crowned aluminium blades made from highly elastic special alloy, making them bend proof, scratch-proof and shockproof. Metal blades gauge size of 0.4 and available in the entire range of blade finishes and sizes.

Standard Finish:

► Polyester 3 layer coil coating with double stove enamel - PE3

Optional Finish:

► Fluor Polymer paint - PVF.2



Double Omega Punching for positive ladder cord attachment



Aluminium skirting detail with 50mm extension



Standard termination detail



Superior quality components in head-rail

Blade widths

Solid, perforated or half perforated are available in all blade widths.

Left column

- ▶ 50mm wide
- ▶ 150mm wide

Right column

- ▶ 80mm wide
- ▶ 100mm wide.

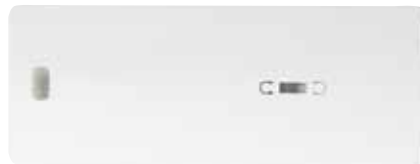

6 Standard Colours

Left column

- ▶ White - RAL 9016
- ▶ Bronze - HOR 7140
- ▶ Tobacco - RAL 8019.

Right column

- ▶ Light Silver - RAL 9006
- ▶ Silver Pearl - RAL 9007
- ▶ Storm Pearl - HOR 7043.

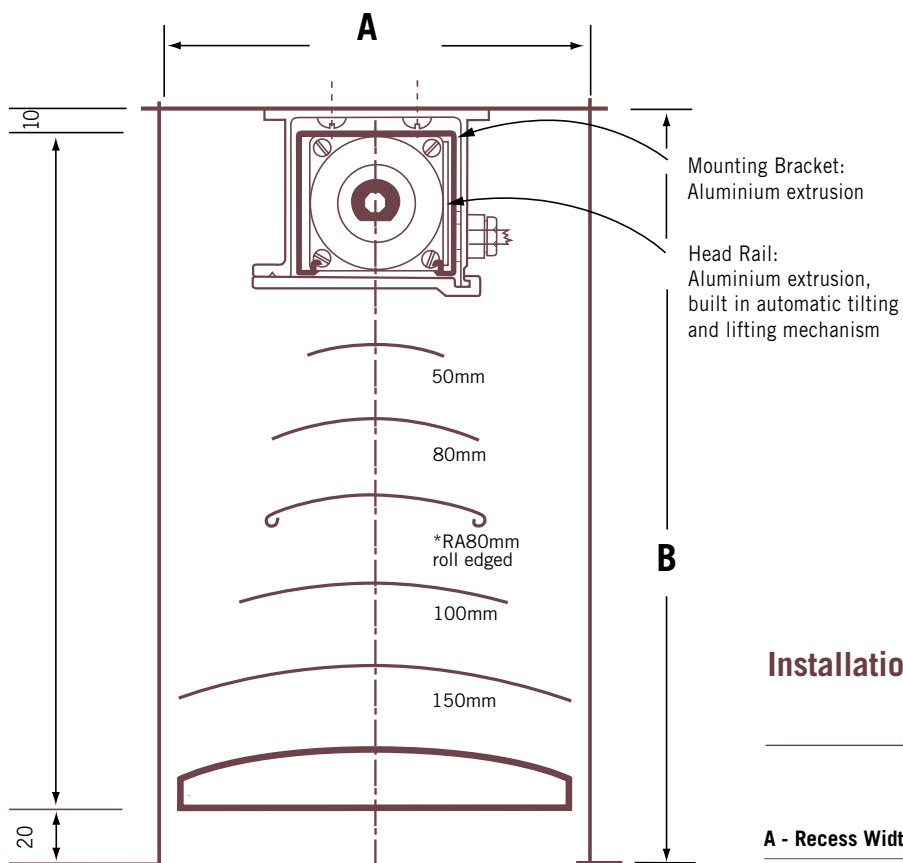

Installation

A - Recess Widths in mm

Blade width		Inside recess widths	
50mm	Horiso® 50	110	
80mm	Horiso® 80	120	
100mm	Horiso® 100	140	
150mm	Horiso® 150	190	

B - Recess Heights in mm

Required inside recess height for an installed height of	Blade width				*Not available indicative dimensions only
	80 AK-S	80 AK-G	100 AK-S	100 AK-G	
1500	151	173	144	166	210
2000	166	188	156	178	245
2500	181	203	169	191	285
3000	196	218	181	203	320
3300	205	227	189	211	-
4000	-	248	-	228	395
5000	-	278	-	253	-
6000	-	308	-	278	-
7000	-	338	-	303	-
8000	-	368	-	328	-
9000	-	398	-	353	-



Daylight Control option

Horiso External Venetian Blinds not only provide shading and glare control, they can also as an option allow daylight in through the upper portions of the blind. Uniquely designed ladder cords allow upper blades to tilt at different angles to the bottom blades, resulting in an integrated 'light shelf' system spreading natural light further into the building while still providing the solar performance of a standard custom blind.

Features

- ▮ Suitable for interior and exterior application, with most effective results in internal environments.
- ▮ Full automation and sun-tracking capabilities via Dynamic Facade Controller.

Benefits

- ▮ Effective control of daylight and solar glare.
- ▮ Reduces the use of artificial lighting.
- ▮ Reduced energy consumption.

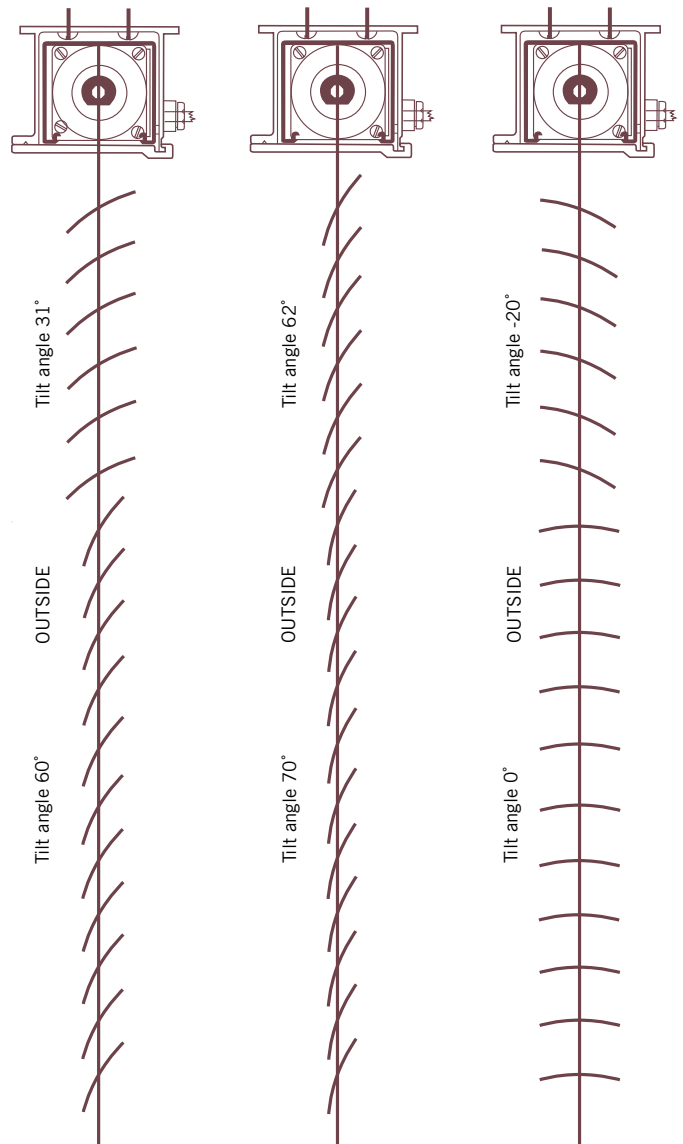



Horiso® Venetian Blinds in double-skin ventilated facades

Architects and builders are now shifting towards designing and constructing buildings with double skin passive and active ventilated facades to lower building energy requirements for heating and cooling.

Double-skin facades have a variable space between their inner and outer glazed skin. Horiso External Venetian Blinds are installed in this space between the two skins, where they serve as a key method of controlling the amount of solar energy that passes into and through this void. The blinds automatically raise, lower and tilt as required depending on environmental conditions.

While more expensive to build than a traditional design, these facades provide significantly higher levels of environmental control and offer both long-term financial and sustainability advantages.



Features

- ▶ In summer, blinds remain partially or fully closed, absorbing and reflecting solar energy to shield the interior from solar gain. Vents at the top and bottom of the void (or on each floor) then open, allowing warm air continually to be replaced with cooler air via the stack effect.
- ▶ In winter, blinds remain mostly open and are operated to maximise passive solar heating, except as needed for glare control. Facade vents remain closed, creating a thermal barrier of warmer air in the void.

Benefits

- ▶ Building energy requirements are lower for heating and cooling.
- ▶ Long-term financial savings.
- ▶ Provides significantly higher levels of environmental control.
- ▶ Controls glare and heat gain effectively.
- ▶ High level of control even for high rise buildings.

Stand-alone control

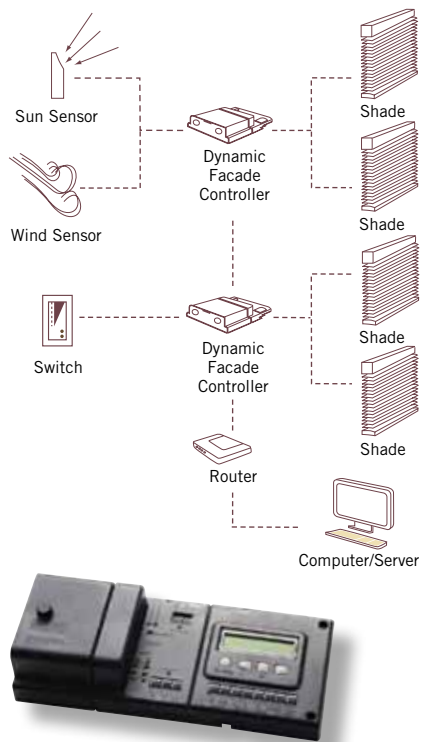

Integrated control

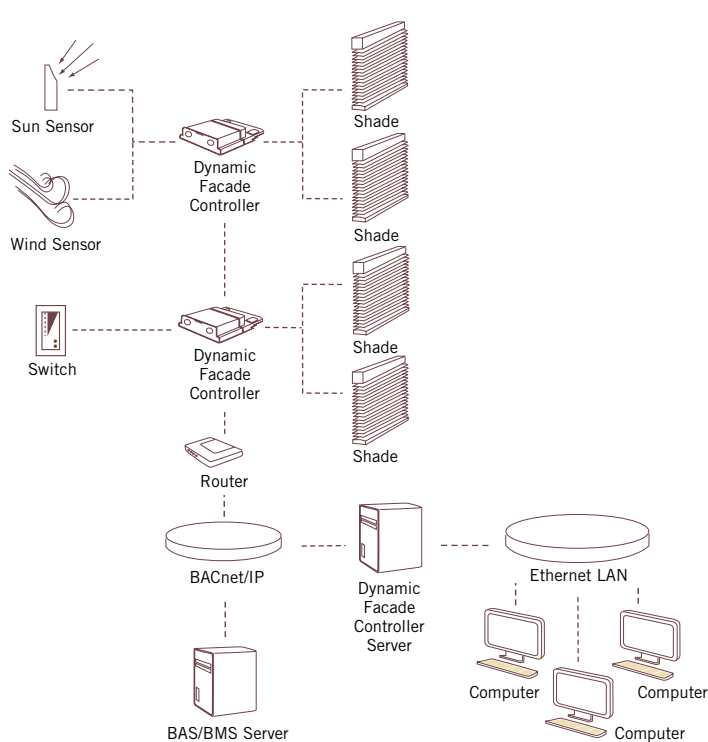

Dynamic Facade Control System

Integrated control solutions for automated building systems achieve new levels of building energy efficiency.

Unique building design calls for unique control solutions. Individual project requirements are established and addressed in the controller programming and commissioning phases. Each controller is programmed with predetermined parameters allowing customised functionality for each building system. This enables each controller to perform effectively as a component of the overall building system.

The Dynamic Facade Controller integrates all operable building envelope systems into a single distributive network. This unique network approach allows each controller to perform individual tasks while cooperating with other building envelope systems.

The Dynamic Facade Controller is a two motor controller designed specifically for the operation of motorised shading systems. In addition to controlling two motors, each controller is capable of accepting six dry contact inputs. Programmable layers allow for the addition of sensors and A/V system integration. The controller operates stand-alone or networked using BACnet/MSTP over RS-485.

The Dynamic Facade Controller manages internal light and glare by responding actively to varying environmental conditions via signals or inputs from

devices such as sun and wind sensors, switches, remotes, timers or a combination of all five. The system is compatible with all shading systems featured in this brochure.

Overall, the Dynamic Facade Control System maximises indoor environmental quality and reduces energy consumption, creating comfortable, productive and sustainable built environments.

Programmable layers include:

- ▶ The capability for each shading device to evaluate how its performance contributes to a specific lighting condition.
- ▶ Sun tracking and scheduling capabilities for time of day, week and/or year.
- ▶ Glare and heat gain control.
- ▶ View displays the entire floor plan of the system, including sensor performance and the status of each shading device.
- ▶ Provides access to system logs, lockout/overrides and alarms.
- ▶ Monitoring and configuration from within a standard web browser.
- ▶ Gives an individual user point-and-click control of shades in their individual area.
- ▶ Supports scene control, scheduling and tweaks.

Project gallery



NZI - Auckland, New Zealand



Private residence - New Zealand



Private residence - Palm Beach, Sydney



GPN 4 University - Brisbane



Horiso® is an Australian manufacturer and supplier of Solar Control Systems.



Horiso® manufactures internal and external solar control systems for the commercial, hospitality, institutional and residential sectors. Our products are sold and installed by an exclusive dealer network of dedicated professionals.



From environmentally friendly internal sunscreens (PVC free) to exterior venetian blinds, architectural products, sun louvres and fully automated systems, Horiso® is a specialised solutions provider for architects.

We deliver market-leading products, unmatched expertise and we will work with you to satisfy your design and engineering challenges.

horiso®

Horiso®

22-26 Myrtle Street Marrickville
NSW 2204 Australia

Telephone (61 2) 8755 4500

Fax (61 2) 8755 4555

Email info@horiso.com

www.horiso.com

Horiso is a registered trademark of Nysan Asia Pacific (NAP Pty Ltd)

June 2010